

SKY 22 LED

HOUSING

TO BE FORMED FROM 20GA CRS
FINISH: ECO WHITE (STANDARD)
ALL STEEL PARTS ARE PHOSPHATE
TREATED FOR CORROSION RESISTANCE
BEFORE PAINT PROCEDURE, THEN
BAKED WITH SUPERIOR ADHESION
FOR DURABILITY

LED MODULES

HIGHER EFFICACY UP TO 170 LPW
WITH SERVICE LIFE GREATER THAN
60000(L70) HIGH COLOR RENDER AND
EXCELLENT COLOR CONSISTENCY
COLOR OPTIONS AVAILABLE FROM
27K TO 40K .
90 CRI LEDS AVAILABLE AS OPTIONAL

DRIVERS

CONSTANT CURRENT, CLASS 2
UNIVERSAL INPUT : 120-277VAC
SOUND RATED A, 54V OUTPUT 0-10V
DIMMING STANDARD .
DALI, ECOSYSTEM AND DMX DRIVERS
ALSO AVAILABLE

REFLECTOR

TO BE FORMED FROM 20GA CRS
FINISH: BAKED WHITE ENAMEL WITH
90% REFLECTIVITY

MOUNTING

FLANGE, SLOT GRID
FLANGELESS, 1⁵/₁₆ GRID(T)
1⁹/₁₆ GRID(T1)



PRODUCT DESCRIPTION

THE SKY LED IS A REGRESSED STYLE FIXTURE GENERATING
HIGH EFFICIENCY LIGHT AND COLOR, FREE OF GLARE. THE
UNIFORMITY OF THE LIGHT DISTRIBUTION ENHANCES THE
AESTHETIC, ARCHITECTURAL FIXTURE DESIGN. **THE SKYLIGHT
TYPE FIXTURE CLOSELY RESEMBLES THE LUMINOUS CEILINGS
OF YESTERYEAR. THE CUSTOM TEXTURED/SAND-BLASTED
LIKE LENS MAXIMIZES THE VISUAL COMFORT PROBABILITY
INDEX FROM ANY POINT IN THE OPEN SPACE. THE LENS IS
FREE FROM STRIATIONS OR HOT SPOTS.**

TYPE: _____

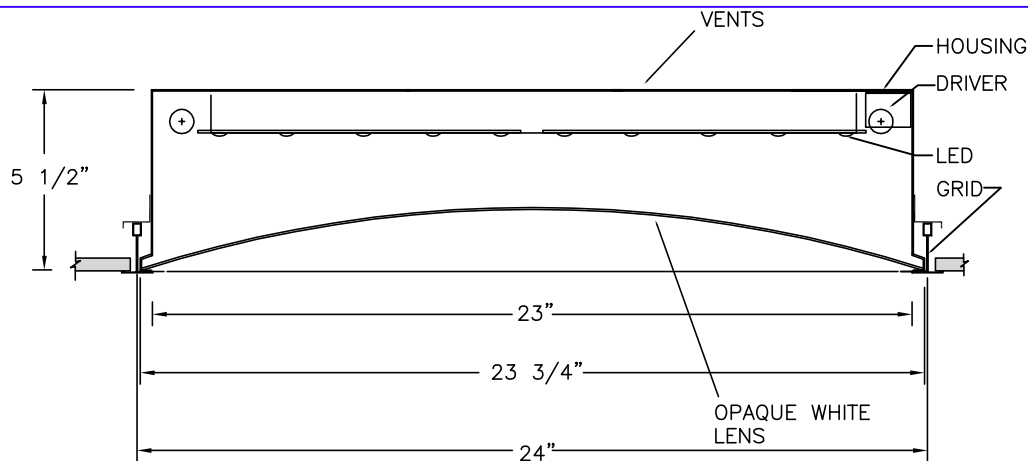

PROJECT: _____

EVEN AND VISUALLY
COMFORTABLE LED
LIGHT DISTRIBUTION
ACROSS PROFILE OF
THE PRODUCT

50% ENERGY
SAVINGS COMPARED
TO LINEAR
FLUORESCENT

SUSTAINABLE
MATERIALS

ARRAY OF LUMEN
OPTIONS ALL
LM79/LM80 UL
APPROVED

5 YEAR WARRANTY
LED AND DRIVER

CEILING OPTIONS

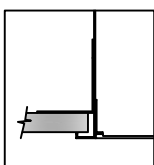

FLANGE(F)

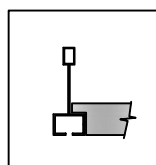

SLOT GRID(SG)

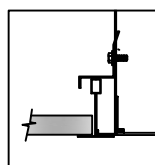

GRID 15/16"(T)

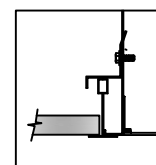

9/16"GRID (T1)

ORDERING KEY

SERIES	LUMENS / (W)	COLOR TEMP	CEILING TYPE	VOLTAGE	OPTIONS
SKY22-LED	<input type="checkbox"/> 2597(25) <input type="checkbox"/> 3463(33) <input type="checkbox"/> 4156(41) Please contact National for other options.	<input type="checkbox"/> 2700K*** <input type="checkbox"/> 3000K <input type="checkbox"/> 3500K <input type="checkbox"/> 4000K <input type="checkbox"/> 5000K	<input type="checkbox"/> T <input type="checkbox"/> F <input type="checkbox"/> SG <input type="checkbox"/> T1	<input type="checkbox"/> 120 V <input type="checkbox"/> 277 V <input type="checkbox"/> UNIVERSAL	<input type="checkbox"/> EM <input type="checkbox"/> DIM 0-10 <input type="checkbox"/> DALI <input type="checkbox"/> Hilume 1% 2 Wire-LTEA2W <input type="checkbox"/> Hilume 1% Eco-LDE1 <input type="checkbox"/> Hilume 5% LDE5

LUMENS WILL VARY
DEPENDING ON DIFFUSER
AND LED COLOR TEMP.

NATIONAL 3E/LED SERIES USES ENGINE/STICK ORIGINAL EQUIPMENT (BY OSRAM, PHILIPS, SAMSUNG, ET AL) WHICH ARE RATED FOR APPROXIMATELY 100 LM/W. ARCHITECTURAL LENSES PROVIDED WITH THE LUMINAIRES BY DESIGN EVEN THE BRIGHTNESS AND VISUAL COMFORT AND MIGHT FRACTIONALLY LOWER LM/W.

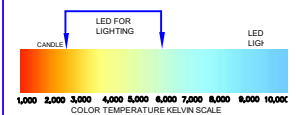

522 CORTLANDT ST.
BELLEVILLE, NJ 07109

NJ 973-751-1600
NY 212-751-1600
FAX 973-751-4931
WWW.NATLTG.COM

Modules and drivers are UL recognized
components and RoHS compliant.
LED modules also comply with IENSA



PHOTOMETRICS

SKY 2X2 LED-LO

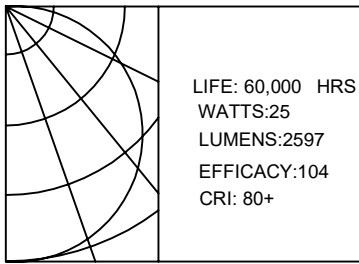

SKY 2X2 LED-MO

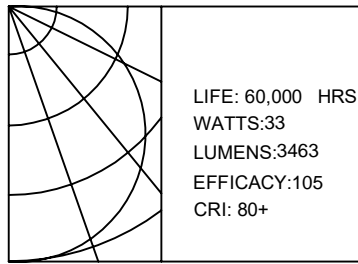

SKY 2X2 LED-HO

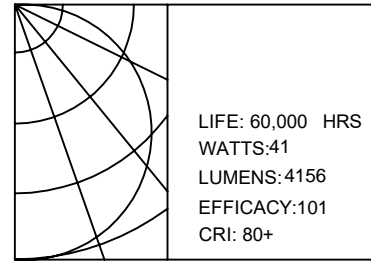

MOUNTING/INSTALLATION INSTRUCTIONS

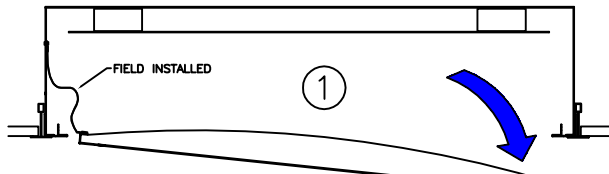

CAREFULLY REMOVE FRAME INSIDE THE HOUSING BY MEANS OF LIFTING AND SHIFTING TO ONE SIDE UNTIL IT DROPS. FRAME HAS SAFETY TETHER FROM FALLING, DO NOT PULL OR TAG - TETHER WILL BREAK.

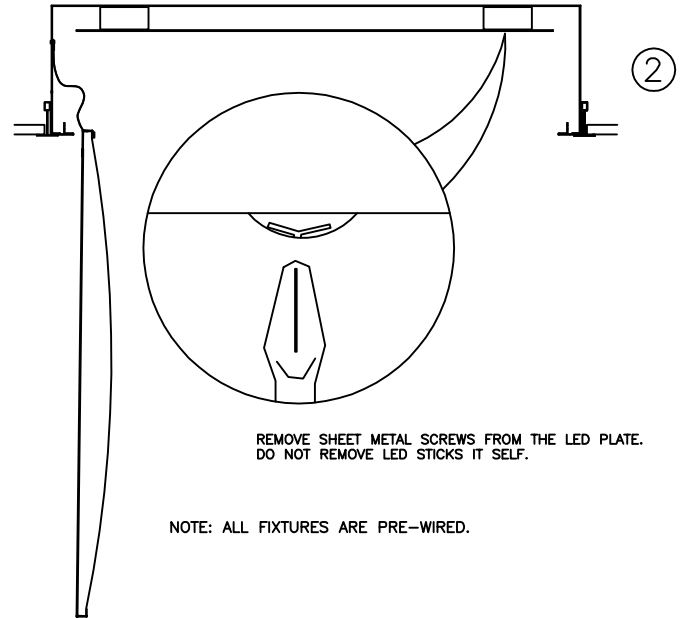

REMOVE SHEET METAL SCREWS FROM THE LED PLATE. DO NOT REMOVE LED STICKS IT SELF.

NOTE: ALL FIXTURES ARE PRE-WIRED.

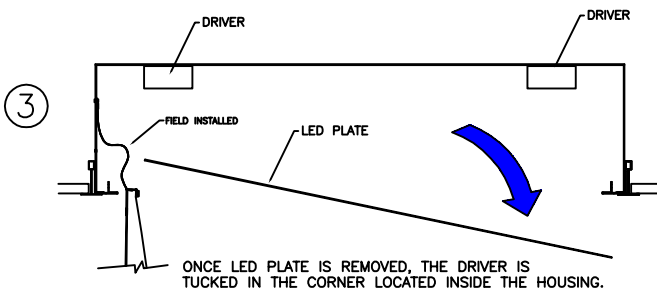

ONCE LED PLATE IS REMOVED, THE DRIVER IS TUCKED IN THE CORNER LOCATED INSIDE THE HOUSING.

GREENFIELD OPTIONS

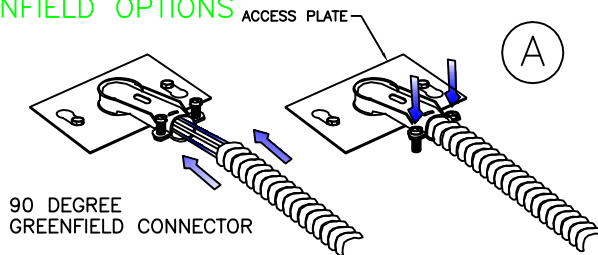

①

②

STRAIGHT CONNECTOR FOR GREENFIELD

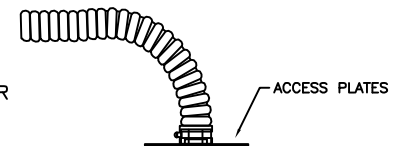

LIGHTING CONTROL SOLUTIONS

1. DIMMING (0-10V, DALI Or Lutron)
 - 0-10V Dimming Driver used as standard.
 - Continuous Dimming up to 10%.
 - Dimming wires not provided unless specified
 - Contact National for Dali or Lutron Control system
2. Occ/DAYLIGHT/Vacancy/Bi-Level
 - Sensor-ready and compatible drivers provided.
 - Sensors can be field installed or could be installed in the fixtures
 - Bi-level dimming and Motion sensors also available
3. Compatibility:
 - National fixtures are compatible with Lutron, Philips Actilume, Magnum, Wattstopper, Hubbell , Leviton , Hytronik , Daintree & Enlighted Control System

DOOR FRAME DETAIL

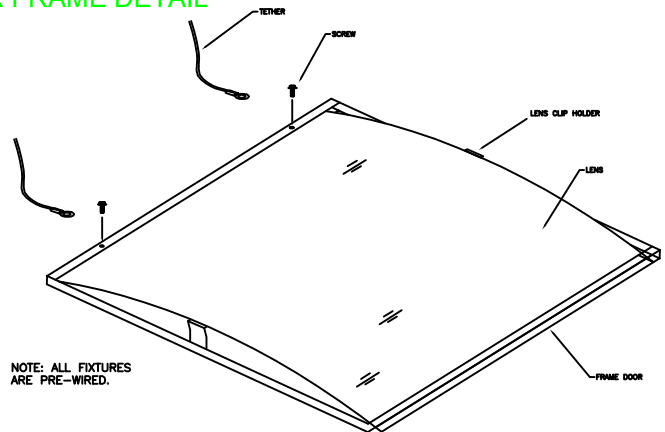

NOTE: ALL FIXTURES ARE PRE-WIRED.

JOB NAME:
CATALOG:
TYPE:



NATIONAL LIGHTING COMPANY, INC.
522 CORTLANDT ST.
BELLEVILLE, NJ 07109

NJ 973-751-1600
NY 212-751-1600
FAX 973-751-4931
WWW.NATLTG.COM