

S14 D/ID LED



HOUSING

THE 1.75 INCHES DEEP HSG TO BE FORMED FROM 20GA CRS. FINISH BAKED WHITE ENAMEL(STANDARD). ALL FIXTURES ARE PRE-WIRED. ALL STEEL PARTS ARE PHOSPHATE TREATED FOR CORROSION RESISTANCE BEFORE PAINT PROCEDURE THEN BAKED WITH SUPERIOR ADHESION FOR DURABILITY.

LED MODULES

HIGHER EFFICACY UP TO 170 LPW WITH SERVICE LIFE GREATER THAN 60000(L70) HIGH COLOR RENDER AND EXCELLENT COLOR CONSISTENCY COLOR OPTIONS AVAILABLE FROM 27K TO 40K .
90 CRI LEDS AVAILABLE AS OPTIONAL

DRIVERS

CONSTANT CURRENT, CLASS 2
UNIVERSAL INPUT : 120-277VAC
SOUND RATED A, 54V OUTPUT 0-10V
DIMMING STANDARD .
DALI, ECOSYSTEM AND DMX DRIVERS ALSO AVAILABLE

REFLECTOR

TO BE FORMED FROM 20GA CRS
FINISH: BAKED WHITE ENAMEL WITH 90% REFLECTIVITY

MOUNTING

AIRCRAFT CABLE, PENDANT OR WALL MOUNTED

PRODUCT DESCRIPTION

THE S14 LED IS SHALLOW 1.75X4.50" ULTRA SLIM COMPACT HOUSING AVAILABLE WITH DIRECT/INDIRECT AND COMPLETELY INDIRECT LIGHTING DISTRIBUTION. A COMPACT REFLECTING SYSTEM IS INTEGRATED INTO THE NARROW CHASIS BECOMES INTEGRATED UNOBTRUSIVELY INTO ANY OPEN OFFICE SPACE BUT AT THE SAME TIME MAKES A CLEAR ARCHITECTURAL STATEMENT. LONG CONTINUOUS RUNS OF CUTTING EDGE LED LIGHTING IS THE HALLMARK OF THE SYSTEM. COLOR ARE THE POWER POINTS OF THIS INNOVATIVE LIGHTING SOLUTIONS

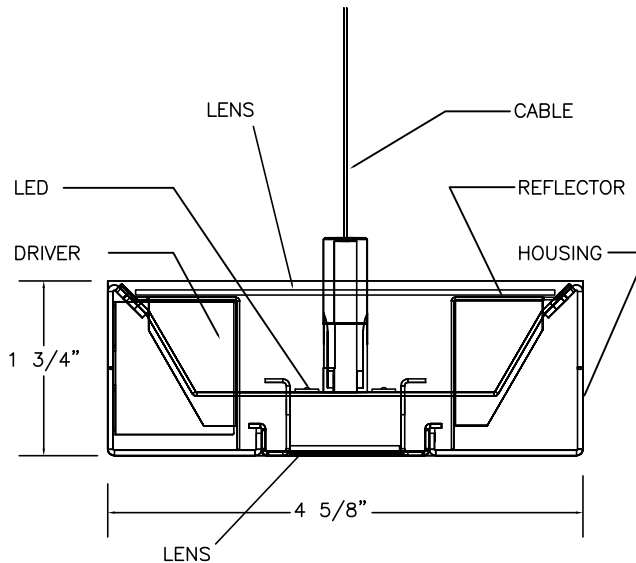

TYPE:

PROJECT:

EVEN AND VISUALLY COMFORTABLE LED LIGHT DISTRIBUTION ACROSS PROFILE OF THE PRODUCT

50% ENERGY SAVINGS COMPARED TO LINEAR FLUORESCENT

SUSTAINABLE MATERIALS

ARRAY OF LUMEN OPTIONS ALL LM79/LM80 UL APPROVED

5 YEAR WARRANTY LED AND DRIVER

SERIES	Lumens/ft (Watts/ft)	LENGTH	COLOR TEMP	MOUNTING	VOLTAGE	OPTIONS
S14D/ID LED	<input type="checkbox"/> LO 862(9) <input type="checkbox"/> MO 1026.25(11.05) <input type="checkbox"/> HO 1211(12.25) Please contact National for other options.	<input type="checkbox"/> 4' <input type="checkbox"/> 8' <input type="checkbox"/> ROWS	<input type="checkbox"/> 2700K <input type="checkbox"/> 3000K <input type="checkbox"/> 3500K <input type="checkbox"/> 4000K <input type="checkbox"/> 5000K	<input type="checkbox"/> AC - CABLE <input type="checkbox"/> P - STEM <input type="checkbox"/> WM - WALL <input type="checkbox"/> 24" <input type="checkbox"/> 48" <input type="checkbox"/> OTHER_____	<input type="checkbox"/> 120 V <input type="checkbox"/> 277 V <input type="checkbox"/> UNIVERSAL	<input type="checkbox"/> EM <input type="checkbox"/> DIM 0-10 <input type="checkbox"/> DALI <input type="checkbox"/> HiLume 1% -2WIRE <input type="checkbox"/> HiLume 1%ECO-LDE1 <input type="checkbox"/> HiLume 5% LDE5

LUMENS WILL VARY DEPENDING ON DIFFUSER AND LED COLOR TEMP

NATIONAL 3ELED SERIES USES ENGINE/STICK ORIGINAL EQUIPMENT (BY OSRAM, PHILIPS, SAMSUNG, ET AL) WHICH ARE RATED FOR APPROXIMATELY 100 LM/W. ARCHITECTURAL LENSES PROVIDED WITH THE LUMINAIRES BY DESIGN EVEN THE BRIGHTNESS AND VISUAL COMFORT AND MIGHT FRACTIONALLY LOWER LM/W.



522 CORTLANDT ST.
BELLEVILLE, NJ 07109

NJ 973-751-1600
NY 212-751-1600
FAX 973-751-4931
WWW.NATLTG.COM

Modules and drivers are UL recognized components and RoHS compliant.
LED modules also comply with IENSA LM-79 and LM-80 standards.

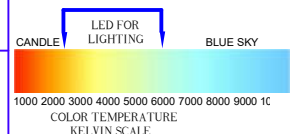

S14 D/ID LED

PHOTOMETRICS

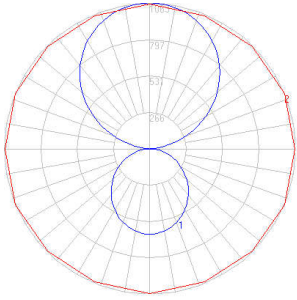

LIFE: 60,000 HRS
WATTS:36
LUMENS:3418
EFFICACY:93
CRI: 80+

S14D/ID LED-LO

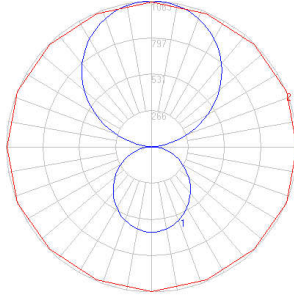

LIFE: 60,000 HRS
WATTS:44.2
LUMENS:4105
EFFICACY:96
CRI: 80+

S14D/ID LED-MO

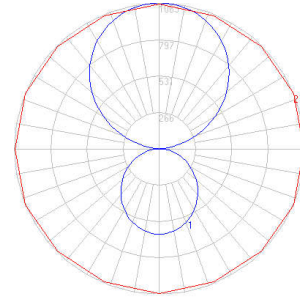

LIFE: 60,000 HRS
WATTS:49
LUMENS:4844
EFFICACY:98
CRI: 80+

S14D/ID LED-HO

MOUNTING INSTRUCTIONS

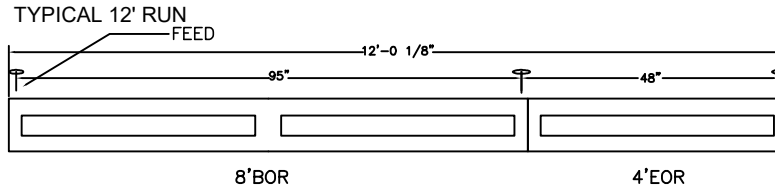

AIRCRAFT CABLE MOUNTING ASSEMBLY WITH POWER CORD

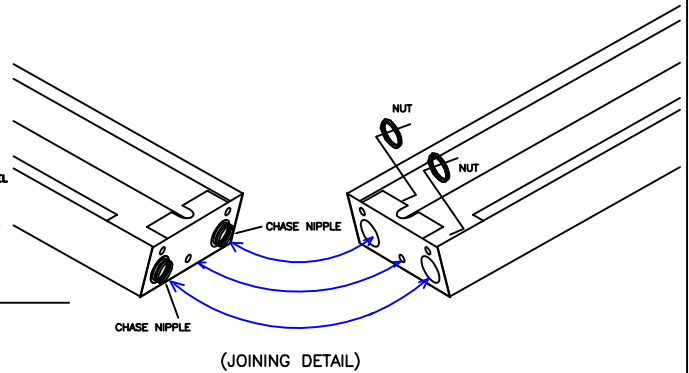
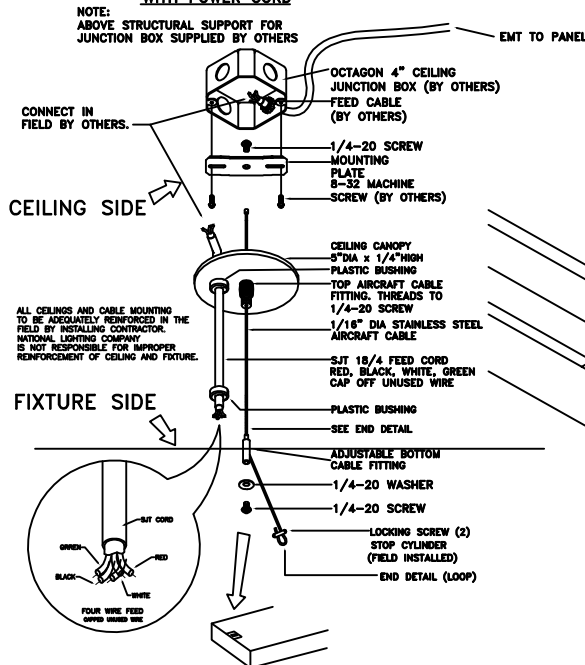

LIGHTING CONTROL SOLUTIONS

- DIMMING (0-10V, DALI Or Lutron)**
 - 0-10V Dimming Driver used as standard.
 - Continuous Dimming up to 10%.
 - Dimming wires not provided unless specified
 - Contact National for Dali or Lutron Control system
- Occ/DAYLIGHT/Vacancy/Bi-Level**
 - Sensor-ready and compatible drivers provided.
 - Sensors can be field installed or could be installed in the fixtures
 - Bi-level dimming and Motion sensors also available
- Compatibility:**

National fixtures are compatible with Lutron, Philips EasySense, Magnum, Wattstopper, Hubbell , Leviton , Hytronik , Daintree & Enlighted Control System

APPLICATION DETAIL



NATIONAL LIGHTING COMPANY, INC.
522 CORTLANDT ST.
BELLEVILLE, NJ 07109

NJ 973-751-1600
NY 212-751-1600
FAX 973-751-4931
WWW.NATLTG.COM

JOB NAME:
CATALOG:
TYPE: