

# AFFINE 2x4 LED

## HOUSING

TO BE FORMED FROM 20GA CRS  
FINISH: ECO WHITE (STANDARD)  
ALL STEEL PARTS ARE PHOSPHATE  
TREATED FOR CORROSION RESISTANCE  
BEFORE PAINT PROCEDURE, THEN  
BAKED WITH SUPERIOR ADHESION  
FOR DURABILITY

## LED MODULES

HIGHER EFFICACY UP TO 170 LPW  
WITH SERVICE LIFE GREATER THAN  
60000(L70) HIGH COLOR RENDER AND  
EXCELLENT COLOR CONSISTENCY  
COLOR OPTIONS AVAILABLE FROM  
27K TO 40K.  
90 CRI LEDS AVAILABLE AS OPTIONAL

## DRIVERS

CONSTANT CURRENT, CLASS 2  
UNIVERSAL INPUT : 120-277VAC  
SOUND RATED A, 54V OUTPUT 0-10V  
DIMMING STANDARD .  
DALI, ECOSYSTEM AND DMX DRIVERS  
ALSO AVAILABLE

## REFLECTOR

TO BE FORMED FROM 20GA CRS  
FINISH: BAKED WHITE ENAMEL WITH  
90% REFLECTIVITY

## MOUNTING

FLANGE, SLOT GRID  
FLANGELESS, 1/16" GRID(T)  
1/16" GRID(T1)

## PRODUCT DESCRIPTION

THE AFFINE LED 2X4 COMBINES DIGITAL LED LIGHTING WITH  
HIGH PERFORMANCE OPTICAL DESIGN. THE ADVANCED  
DESIGN OF THE LED AFFINE 2'X4' OFFERS HIGH EFFICACY,  
50000 HOURS OF LIFE AND EXCELLENT COLOR FOR  
GENERAL AMBIENT LIGHTING APPLICATIONS. THE LINEAR  
INTEGRAL PRISMS OF THE TRANSLUCENT LENS  
DISTRIBUTES LIGHT EVENLY INTO THE SPACE WHILE  
MINIMIZING CONTRAST BETWEEN THE FIXTURE AND CEILING

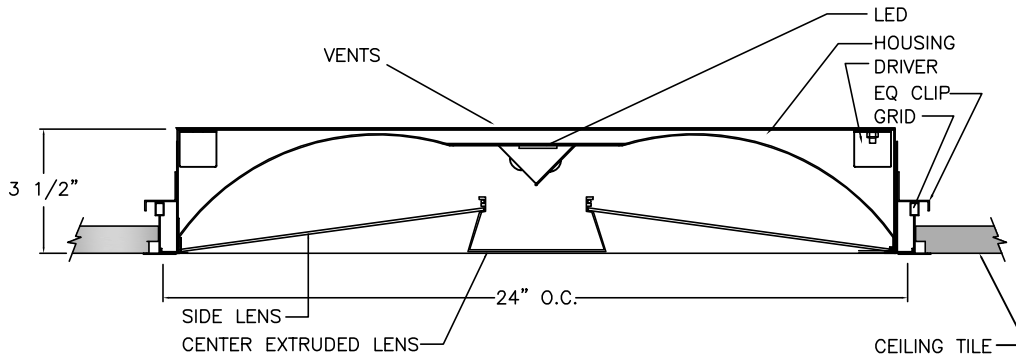
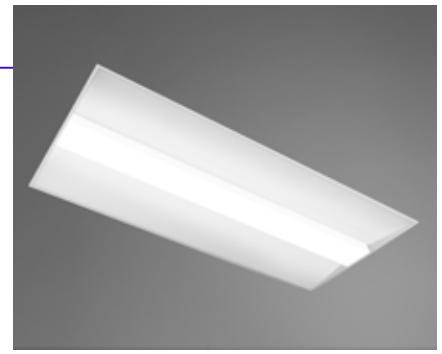

## CEILING OPTIONS

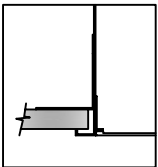

FLANGE(F)

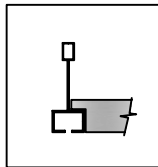

SLOT GRID(SG)

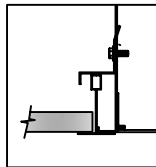

GRID (T)

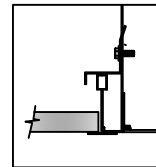

9/16"GRID (T1)

## ORDERING KEY

SERIES	LUMENS (WATTS)	COLOR TEMP	CEILING TYPE	VOLTAGE	OPTIONS
AFF24LED	<input type="checkbox"/> 4078(43W) <input type="checkbox"/> 5035(51.8W) <input type="checkbox"/> 6042(62W) Please contact National for other options.	<input type="checkbox"/> 2700K** <input type="checkbox"/> 3000K <input type="checkbox"/> 3500K <input type="checkbox"/> 4000K <input type="checkbox"/> 5000K Contact National For 2700K Option	<input type="checkbox"/> T <input type="checkbox"/> F <input type="checkbox"/> SG <input type="checkbox"/> T1	<input type="checkbox"/> 120 V <input type="checkbox"/> 277 V <input type="checkbox"/> UNIVERSAL	<input type="checkbox"/> EM <input type="checkbox"/> 0-10V <input type="checkbox"/> DALI <input type="checkbox"/> LDE1 - Eco1% <input type="checkbox"/> L3DA-3Wire or Eco1% <input type="checkbox"/> SENSOR(OCC/VAC) <input type="checkbox"/> WHIPS

LUMENS WILL VARY  
DEPENDING ON DIFFUSER  
AND LED COLOR TEMP.

NATIONAL 3E/LED SERIES USES ENGINE/STICK ORIGINAL EQUIPMENT (BY OSRAM, PHILIPS, SAMSUNG, ET AL) WHICH ARE RATED FOR APPROXIMATELY 150 LM/W. ARCHITECTURAL LENSES PROVIDED WITH THE LUMINAIRE BY DESIGN EVEN THE BRIGHTNESS AND VISUAL COMFORT AND MIGHT FRACTIONALLY LOWER LM/W.

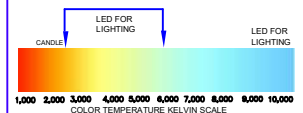

TYPE:

PROJECT:

EVEN AND VISUALLY  
COMFORTABLE LED  
LIGHT DISTRIBUTION  
ACROSS PROFILE OF  
THE PRODUCT

50% ENERGY  
SAVINGS COMPARED  
TO LINEAR  
FLUORESCENT

SUSTAINABLE  
MATERIALS

ARRAY OF LUMEN  
OPTIONS ALL  
LM79/LM80 UL  
APPROVED

5 YEAR WARRANTY  
LED AND DRIVER



NJ 973-751-1600  
NY 212-751-1600  
FAX 973-751-4931



# PHOTOMETRIC DATA

## AFFINE 2X4 LED-LO

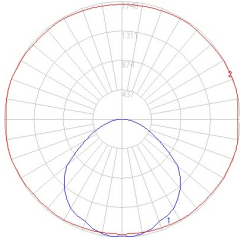

LIFE: 60,000 HRS  
 WATTS:43  
 LUMENS:4078  
 EFFICACY:95  
 CRI: 80+

## AFFINE 2X4 LED-MO

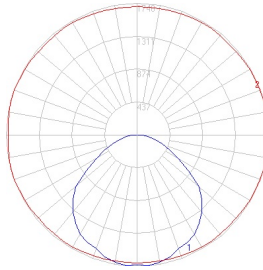

LIFE: 60,000 HRS  
 WATTS:51.8  
 LUMENS:5035  
 EFFICACY:97  
 CRI: 80+

## AFFINE24 LED-HO

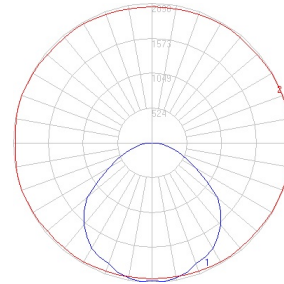

LIFE: 60,000 HRS  
 WATTS:62  
 LUMENS:6042  
 EFFICACY:97  
 CRI: 80+

## MOUNTING INSTRUCTIONS

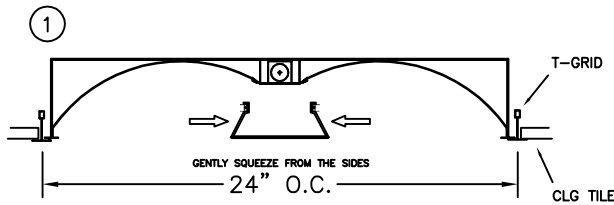

ABOVE CEILING STRUCTURE AND SUPPORT TO BE SUPPLIED BY OTHERS.

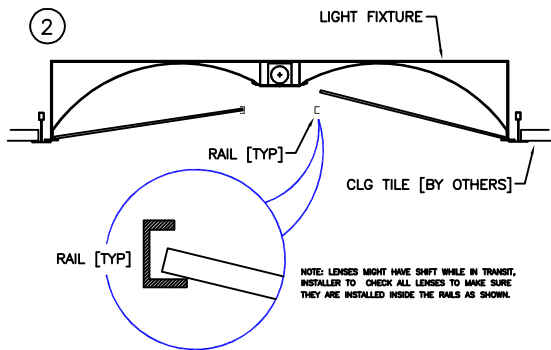

NOTE: ALL PLASTIC SIDE PANELS ARE TO BE FIELD INSTALLED BY OTHERS.

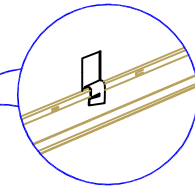
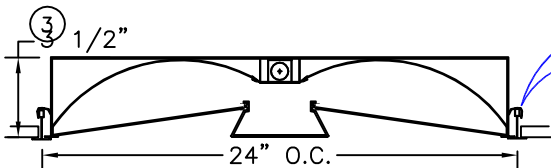
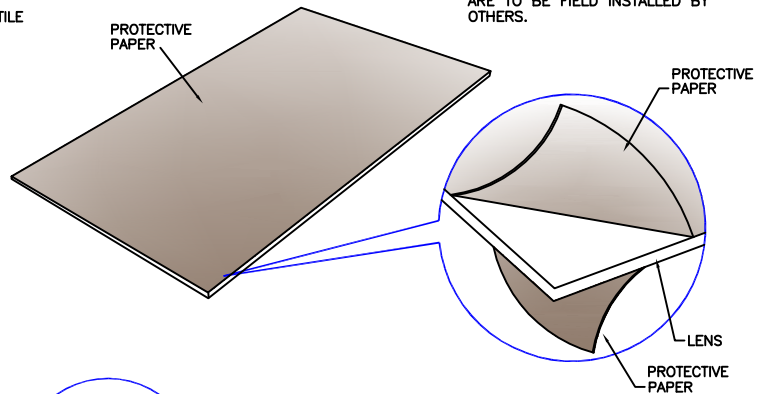

FOR E.Q. CLIP BEND TABS AS SHOWN (TYPICAL)

## LIGHTING CONTROL SOLUTIONS

- DIMMING ( 0-10V, DALI Or Lutron )**
  - 0-10V Dimming Driver used as standard.
  - Continuous Dimming up to 10%.
  - Dimming wires not provided unless specified
  - Contact National for Dali or Lutron Control system
- Occ/DAYLIGHT/Vacancy/Bi-Level**
  - Sensor-ready and compatible drivers provided.
  - Sensors can be field installed or could be installed in the fixtures
  - Bi-level dimming and Motion sensors also available
- Compatibility:**

National fixtures are compatible with Lutron, Philips Actilume, Magnum, Wattstopper, Hubbell , Leviton , Hytronik , Daintree & Enlighted Control System

## GREENFIELD OPTIONS

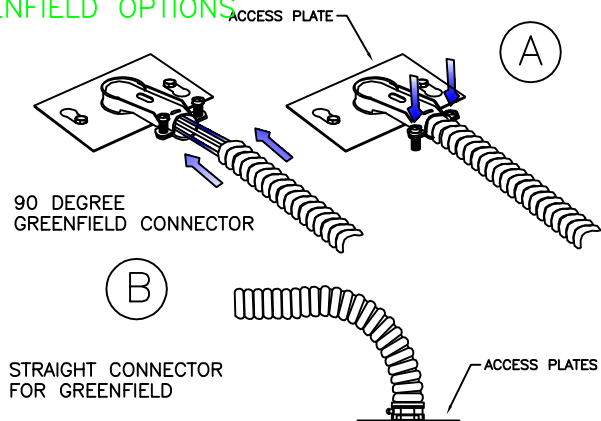

NATIONAL LIGHTING COMPANY, INC.  
 522 CORTLANDT ST.  
 BELLEVILLE, NJ 07109

NJ 973-751-1600  
 NY 212-751-1600  
 FAX 973-751-4931  
 WWW.NATLTG.COM

JOB NAME:	
CATALOG:	
TYPE:	